

PONSSE

**TOUGH
DEBARKER**

**H7
HD
EUCA**



PONSSE H7 HD EUCA

TOUGH DEBARKER





H7 HD EUCA is largely designed by its users. Design based on customer feedback has sparked a eucalyptus harvester head, which truly works and lasts long. It is based on the HD product range, whose popularity is based on having harvester heads in operation, not at the repair shop. The structure, reinforced in various ways, makes H7 HD Euca a durable tool. But, regardless of the reinforced structure, H7 HD Euca is very light and nimble. It makes working smooth and keeps fuel economy high relative to productivity.

Built very durable as requested by customers, H7 HD Euca is a sturdy, but light, harvester head, in which no feature is a compromise. They all represent a customer-driven approach and the highest level of technology. Fast sawing, combined with precise and strong three-roller feeding, guarantees highly efficient debarking and delimiting. The harvester head, light weight considering its very strong structure, has a low consumption, but high productivity.

The material thickness of the saw box and tilt frame has been increased considerably in just the right places to ensure maximised durability, without adding any unnecessary weight. Easy-to-use automatic functions guide saw movements according to the tree diameter and saw bar position, and guarantee fast cutting. This increases the efficiency of sawing and extends the service life of the saw bar and chain. The saw can be calibrated easily by the push of a button. The grapple's tilting force and speed are based on the harvester head's superior geometry.

The PONSSE Opti control system has been designed specifically for PONSSE harvester heads. All adjustments and settings work ideally with the harvester head. Diverse functions are easy to use on the Opti measuring device according to work requirements. With PONSSE systems, production and operations can be monitored on mobile devices.



 630 mm (24.8 in)	 1 300 kg (2,866 lbs)
 25 kN / 30 kN (5 620 lbf / 6 744 lbf)	 640 mm (25.2 in)

H7

HD

EUCA

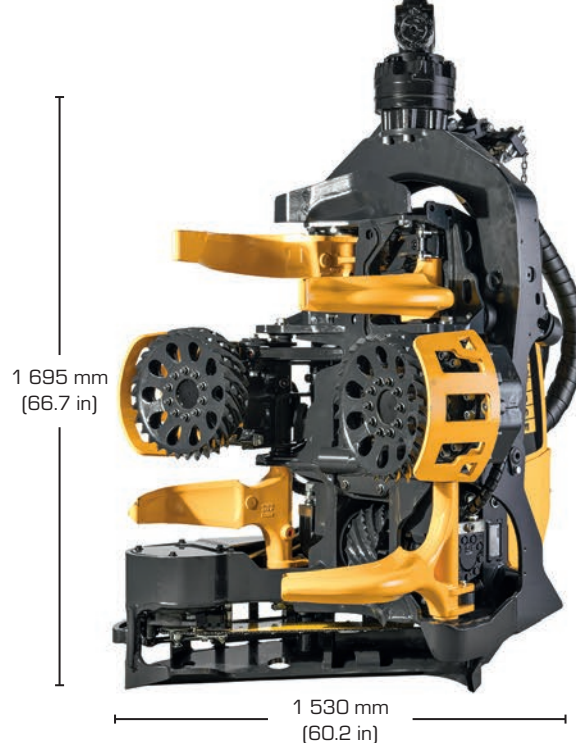

DIMENSIONS

Dry Weight, min. (without rotator):	1 300 kg (2,866 lbs)
Length:	1 545 mm (60.8 in)
Height without rotator:	1 695 mm (66.7 in)
Width:	1 530 mm (60.2 in)
Power consumption:	130–140 kW
Operating pressure:	28 Mpa (4,061 psi)
Oil flow requirement:	280–300 l/min

SAW UNIT

Hydraulic chain saw

Saw motor:	30/32 cc
Power:	45 kW
Saw bar length:	750 mm (29.5 in)
Chain speed:	40 m/s
Chain pitch:	0.404"
Cutting diameter:	640 mm (25.2 in)

FEEDING UNIT

Feeding type:	3 rollers	
Feeding motors:	520/315cc	620/400cc
Feeding force:	25 kN (5 620 lbf)	30 kN (6 744 lbf)
Feeding speed:	0–6 m/s	0–5 m/s
Max. opening:	630 mm (24.8 in)	

DELIMITING UNIT

One bolted and adjustable (2cm) + 4 movable knives (+ 1 fixed rear knife)	
Max. opening, front/rear:	620/730 mm (welded) (rollers 630mm)
Max. opening, front/rear:	610/730mm (casted) (rollers 630mm)
Delimiting knives and feed rollers separately controllable, adjustable pressure for knives and rollers.	



Ponsse Plc
Ponssentie 22
FI-74200 Vieremä
FINLAND
Tel. +358 20 768 800
www.ponsse.com

PONSSE

A logger's best friend

www.ponsse.com