

BEAVER

PONSSE

***AN AGILE
SIX-WHEELER***





PONSSE BEAVER

AN AGILE SIX-WHEELER

PONSSE Beaver feels at home at dense thinning sites, while it is a reliable harvester at all sites where a durable base machine is needed. The agility of a six-wheeler, combined with a solid structure, makes PONSSE Beaver unstoppable, even at difficult thinning sites. Agility calls for a small turning radius and a short frame. This is why Beaver is at its best at rocky logging sites and other sites where agility is needed.

PONSSE BEAVER

makes working easy. It does not require any large transportation vehicle, and its operating costs are low. Its excellent visibility and high-reach crane make working easy, especially in thinning sites.

CABIN AND CONTROL SYSTEM

The most spacious and comfortable cabin and the most ergonomic controls in the market guarantee the best working comfort. The PONSSE Opti information system is an advanced and easy-to-use interface for machine and work management.

ENGINE AND HYDRAULICS

The large 190 m³ work pump offers the best hydraulic capacity in the size class and the mighty Mercedes-Benz engine ensures that power never runs out, while fuel economy remains high.

FRAME STRUCTURES

The design of the Beaver frame focuses particularly on durability and ease of maintenance. Beaver's chassis structure is based on a short wheelbase and a free-floating portal axle. Combined, these result in an agile all-terrain solution for demanding thinning conditions.

SIX WHEELS

With its six wheels, PONSSE Beaver is an agile harvester, and its stability is provided by its sturdy frame joint and swing axle, which can be locked during work using hydraulic cylinders.



CRANE

The PONSSE C44+ parallel crane, with parallel action, uses hydraulics instead of mechanical leverage. This is why the crane is fuel-efficient, powerful and requires less maintenance. Ponsse designs and manufactures all of its crane models for high-quality and well-functioning crane-base machine combinations.

HARVESTER HEADS

PONSSE harvester heads are known for their high efficiency/weight ratios and durable structure, which are second to none. A broad harvester head range is available for Beaver: choose the small and feisty H5 for thinning-based harvesting or the light and efficient H6 as an all-round grapple for larger logging sites.



CABIN

WORKPLACE WITH A VIEW

The Beaver has no obstacles to productivity in sight.

The PONSSE Beaver cabin is your vantage point to the latest in forest machine technology. It is a work environment for professionals who value comfort, safety and ergonomics.

The control devices are the best you will find in forest machines in terms of their ergonomics. The large cabin, expansive windows and thin window pillars ensure excellent visibility in all directions.

Optionally the cabin can also be equipped with the best forest machine seat in the world, PONSSE Seat.



PONSSE SEAT *

UNBEATABLE COMFORT

THE ONLY SEAT ON THE MARKET SPECIALLY DESIGNED FOR FOREST MACHINE DRIVERS.

COMFORT ABOVE ALL ELSE.

The breathable fabric and ergonomic seat supports, guarantee improved working comfort.

DURABLE AND EASILY MAINTAINABLE FABRIC.

Seat fabric is especially durable and the dirt repellent surface makes cleaning effortless.



DURABLE AND STABLE BASE.

A strong base provides the seat with superior reliability and stability. Thanks to the suspension specifically designed for forest machines, the PONSSE Seat decreases effectively swinging and impacts towards the operator.

EASY ACCESS TO SEAT CONTROLS AND BASE.

All adjustment controls are conveniently located at the front of the seat cushion. The removable cushion gives easy access to the seat base for maintenance.

* PONSSE Seat is available as option to all PONSSE machines.



**ACTIVE
CARE**

**LESS SERVICE,
MORE OPERATION**

The technology and hydraulics offer longer service intervals, increasing effective operating hours and reducing operating costs. Easy access to important components speeds up maintenance. In all PONSSE models special attention has been put into the positioning of components and service points, as well as the ease of maintenance, as requested by our customers.

ENSURE MAXIMUM PRODUCTIVITY

PONSSE Active Care service agreements offer the best possible service for forest machine entrepreneurs. You can focus on your logging, while Ponsse will make sure that the machine will maintain its performance and productivity from one logging site to the next. With the PONSSE Active Care service agreement, you can outsource the scheduled maintenance of your forest machine to Ponsse. Machines are maintained regularly by our professionals using only high-quality and original PONSSE parts, lubricants and filters to keep the machines in good operating condition to retain its value.



MERCEDES-BENZ ENGINES

CLEANER AND MORE EFFICIENT

Explosive power and increased torque. Lower emission level and fuel consumption.

The new Mercedes-Benz STAGE V emission engines are efficient and economical. The torque has been increased, and maximum torque can be reached at lower engine speeds.

The Mercedes-Benz STAGE V emission engines are modern, low-emission engines with significantly lower particulate matter (PM) and nitrogen oxide (NOx) emissions compared to engines of the previous emission levels (STAGE III and IV).

In addition to particulate matter, the STAGE V engines also now control particulate volume with a particulate filter (DPF).

Outside Europe an EU Stage V/Tier 4F or Stage IIIA level Mercedes-Benz engine is used depending on market specific emission requirements.

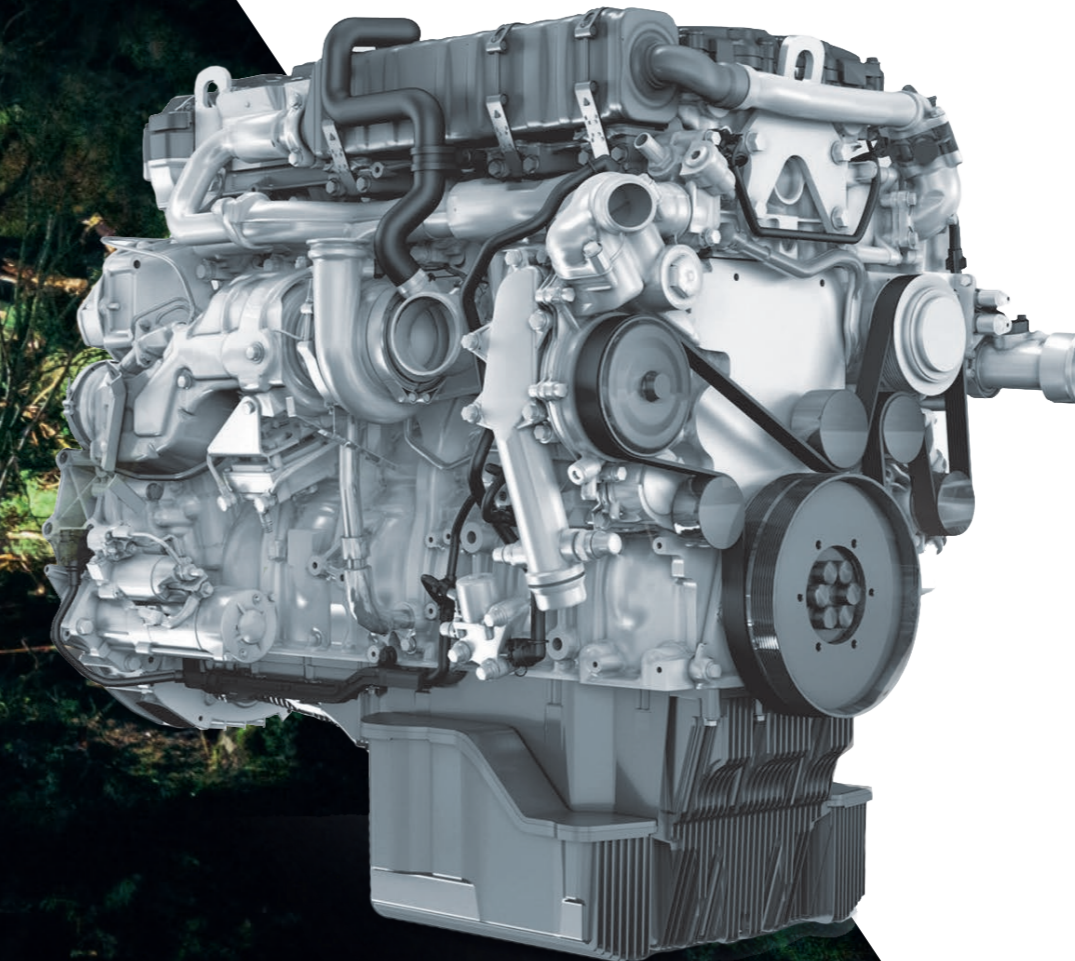

Our goal is to manufacture the most productive and economical forest machines on the market. We call this the PONSSE Boost/Save operating model.

At Ponsse, we have always put the customers first.

For decades now, we have been developing the world's best cut-to-length forest machines as well as related services and information systems. The users of the machines are the best specialists in their field, and we closely listen to their feedback. Together, we have managed to continue increasing the productivity and efficiency of harvesting and reduce the costs. This has been the result of long-term collaboration. However, we want to serve our customers even better.

Boost/Save means even more efficient products and better services for our customers. It means efficient and productive machines, agile product development, thorough training, comprehensive maintenance, original spare parts and the most modern information systems in the field.

Boost/Save means efficient and productive harvesting!

PONSSE BOOST/SAVE ***POWER AND SAVINGS***



PONSSE MANAGER ***REAL-TIME MANAGEMENT***

PONSSE Manager connects forest machines to an information network.

PONSSE Manager, the modern digitalization platform for forest machines, enables comprehensive services now and in the future. The easy-to-use tool offers assistance in harvesting equipment maintenance and work planning, along with providing access to functional and extensive reporting.

PONSSE Manager provides real-time information on equipment performance and work site status. The solution can be easily used via a smartphone, tablet or computer.



PONSSE BEAVER

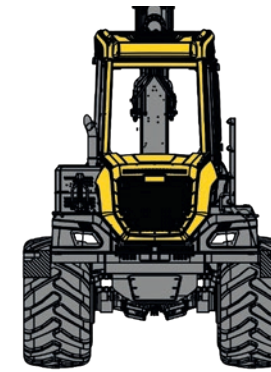
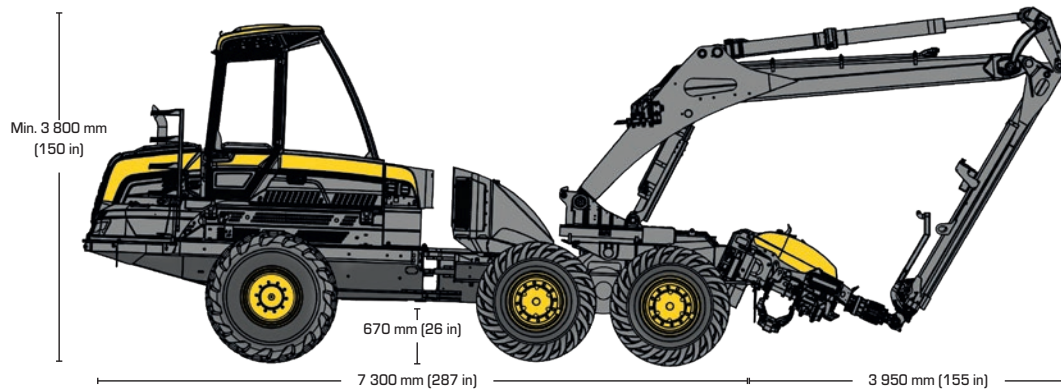

DIMENSIONS

Length:	7 300 mm (287 in)
Width:	2 750-3 085 mm (108-121 in)
Transportation height:	3 800 mm (150 in)
Minimum weight:	16 700 kg (36,817 lb)
Typical weight:	17 700 kg (39,022 lb)
Ground clearance:	670 mm (26 in)

ENGINE

Model:	MB OM 934 LA EU Stage V MB OM 934 LA EU Stage V/Tier 4F MB OM 924 LA Stage IIIA
Power:	EU Stage V and EU Stage V/ Tier 4F: 150 kW (204 hp) Stage IIIA: 145 kW (197 hp)
Torque:	EU Stage V & EU Stage V/Tier 4F: 850 Nm (1 200 – 1 600 rpm) Stage IIIA: 705 Nm (1 200 – 1 600 rpm)
Tractive force:	130 kN (29,225 lbf)
Fuel tank volume:	300 l (79.2 gal US)

TIRES

Front:	650/65-26,5" or 750/55-26,5"
Rear:	600-26,5", 710-26,5" or 800-26,5"

HYDRAULIC SYSTEM

Control system:	PONSSE Opti Control
Working pump:	190 cm ³ (11.6 cu in)
Oil tank volume:	200 l (53 gal US)

CRANE

Model:	PONSSE C44+
Slewing torque (gross):	40 kNm
Crane tilt angle:	-12°/+18°
Turning angle:	250°
Lifting moment (gross):	230 kNm
Reach:	10–11 m (33-36 ft)

* 11 m only with harvester head H5

HARVESTER HEAD

Model:	PONSSE H5
	PONSSE H6

In addition to the comprehensive standard equipment, plenty of optional equipment is available for the PONSSE Beaver. Consult your nearest PONSSE retailer for more information on our standard and optional equipment.



Ponsse Plc

Ponssentie 22
FI-74200 Vieremä
FINLAND
Tel. +358 20 768 800
www.ponsse.com

Ponsse UK Ltd.

4 Annan Business Park
Annan
Dumfriesshire
DG12 6TZ
UNITED KINGDOM
Tel. + 44 1461 207 510

Ponsse Machines Ireland Ltd

Cappakeel, Emo
Portlaoise
R32NN28
Laois
IRELAND
Tel. +353 57 863 3762

Ponsse North America, Inc.

4400 International Lane
Rhineland, WI 54501
USA
Tel. +1 715 369 4833
Fax +1 715 369 4838



A logger's best friend
www.ponsse.com